

New floating bowl molds from Gruber Systems for 2016!

Freshen up your 2016 product offerings with these two new floating bowl mold designs from Gruber Systems. These two new designs are sure to be popular with your customers. Both should be cast with no overflow. For more information, contact Marshall-Gruber Company at 866-260-6457, or email info@marshall-gruber.com

NEW! Ramp Bowl 14" x 20"

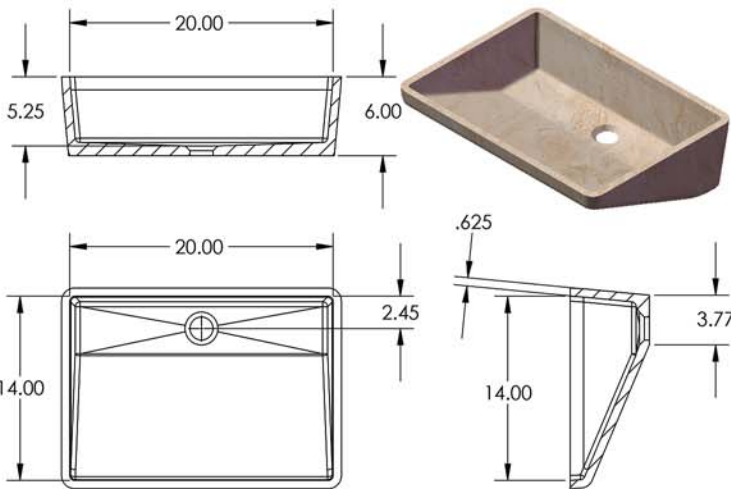

MOLD PART	CATALOG No.	DESCRIPTION
MALE	20143	108 - 14 x 20 Ramp Bowl
FEMALE	401437	Fem - 14 x 20 Ramp Bowl
PERMANENT HAT		
REUSEABLE HAT		
NAME	14 x 20 Ramp Bowl	
CAST WEIGHT	Approx. 28 Lbs	SCALE None
DATE	12.15.15	PAGE No.

NEW! Drop Wave 12" x 18"

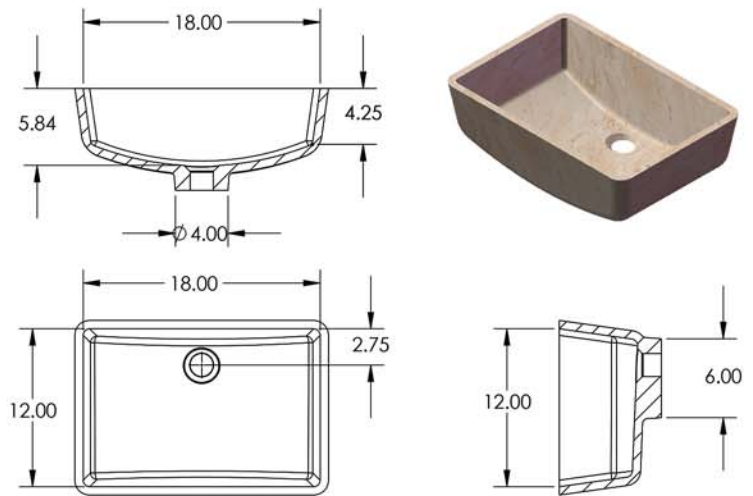

MOLD PART	CATALOG No.	DESCRIPTION
MALE	20142	108 - 12 x 18 Drop Wave
FEMALE	401427	Fem - 12 x 18 Drop Wave
PERMANENT HAT		
REUSEABLE HAT		
NAME	12 x 18 Drop Wave	
CAST WEIGHT	Approx. 25 Lbs	SCALE None
DATE	12.15.15	PAGE No.